

METROPOLITAN QUARRY

Ceramic Floor
& Wall Tile



floridatile

METROPOLITAN QUARRY

by **floridatile**

Florida Tile's Metropolitan Quarry has the distinction of being an unglazed ceramic tile, made in the United States, which can be installed inside or out, is frost proof and maintains high-quality style, and durability. Color throughout the body of the tile supports wearability and natural high density, all-weather performance. Wearing over time produces a natural patina and deeper character. Where performance and style is required, Metropolitan Quarry is the right choice. The modular sizes and blendable colors of this indoor/outdoor unglazed quarry tile support an unlimited palette of pattern combinations.

QuarryBasics® - Clear Tones 6 x 6 • 8 x 8



77310
Mayflower Red

77507
Puritan Gray

QuarryBasics® - X-Colors 6 x 6 • 8 x 8

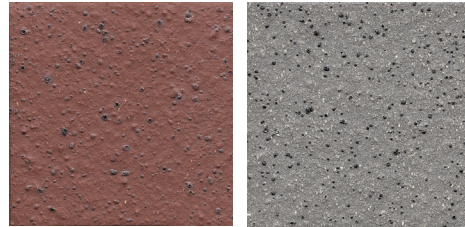

7731X
Commercial Red

7757X
Stone Gray

MetroTread® 6 x 6



7731T
Red

7757T
Gray

Typical Uses

Metropolitan Quarry ceramic floor and wall tile is appropriate for all interior and exterior wall, countertop and backsplash applications.

Notice: Not all flooring products are suitable for wet areas, specialized applications or commercial use. Please refer to the American National Standard Specifications for Ceramic Tile (ANSI A137.1) for ceramic, stone and glass installation for specific usage and installation information.

This Florida Tile product will contribute to USGBC LEED points and the ANSI approved NAHB Green Building Points.

Properties (Floor)	ASTM	ANSI	Results ¹
DCOF AcuTest ²	A137.1	≥ 0.42	Pass
Visible Abrasion Resistance	C-1027	As Reported ³	IV
Glaze Hardness	Mohs Scale	N/A	6 Mohs
Break Strength	C-648	250 lbs.	400 lbf. avg.
Water Absorption	C-373	<3%	<3%

¹ These tests are performed by a 3rd party testing lab using industry standard equipment and techniques. Values are offered in good faith as being accurate and typical of normal production. Due to the natural variation of raw materials and manufacturing processes, the values of the purchased product for any particular installation may vary.

² ANSI A137.1 standard, ceramic tiles selected for level interior spaces expected to be walked upon when wet must have a minimum wet DCOF AcuTest value of 0.42.

³ Class 0 Not recommended for floors, Class I Light Residential, Class II Residential, Class III Heavy Residential or Light Commercial, Class IV Commercial, Class V Heavy Commercial.

Nominal Size ¹	Metric (cm)	Thickness ³	Pcs./Sq Ft ²
8" x 8"	15 x 15	12.7mm	2.25
6" x 6"	13 x 13	12.7mm	4

¹ These values may vary from lot to lot.

² These values are based on actual sizes including the grout joint.

³ May not apply to textured surfaces or tiles with uneven back patterns.

Trim

Available in 77310 and 77507 only

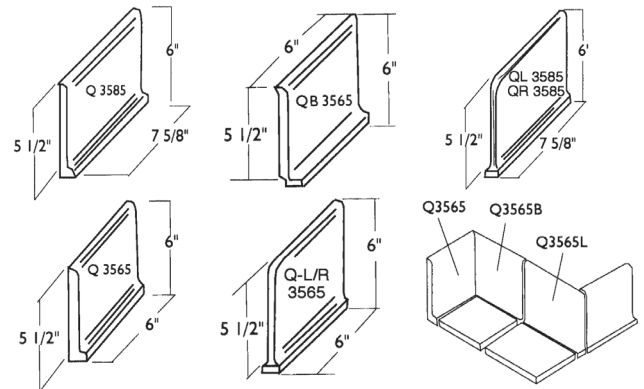

Available in 77310, 77507, 7731X and 7757X

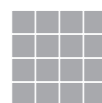
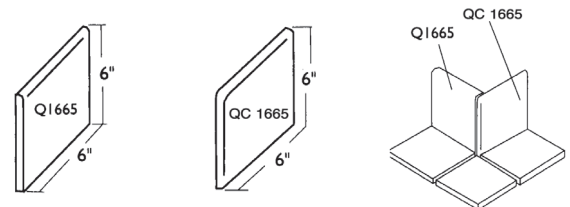

V1 = Uniform Appearance

Differences among pieces from the same production run are minimal.



floridatile